

CMM System - Vibration Display Rack Module VDR

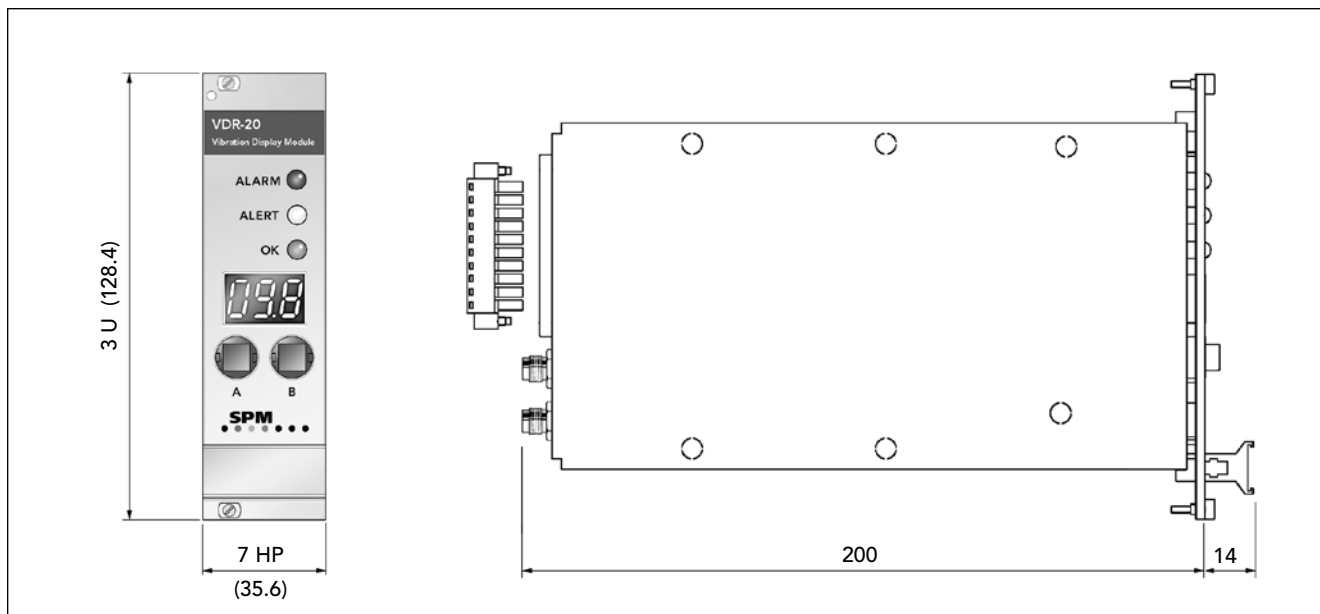

Vibration Display Rack Modules VDR have two functions:

- they measure the RMS-value of vibration velocity on one or two channels and convert it to an analog 4-20 mA signal which can be sent to a PLC.
- they display the analog 4-20 mA signal as a 3 digit measured value. All units have two inputs for analog 4-20 mA, connected to the value display, the condition display and the alarm relays. The analog signal normally comes from the unit's measuring channel(s), but can even come from external sources.

There are four versions:

VDR-14: 1 vibration channel, frequency range 10-1000 Hz

VDR-15: 1 vibration channel, frequency range 3-1000 Hz

VDR-20: 2 vibration channels, frequency range 10-1000 Hz

VDR-21: 2 vibration channels, frequency range 3-1000 Hz.

The vibration transducer is connected via coaxial cable. The modules are mounted in standard 19" racks and supplied with 12 to 24 V DC. The cable inlet is tight for cable diameters 5.5 to 10 mm. A transducer line fault causes an output of <1 mA. If this should interfere with PLC operations, the min. output can be jumper set to 4 mA, individually for each measuring channel.

The display circuit acts as a programmable ampere meter with two channels. Using two push-buttons, one can select preprogrammed measuring units and ranges from a list and set two alarm levels (with alarm delay) for each channel. These are connected to the condition display (green - yellow - red) and to two relay outputs. The relays can be controlled by either display channel. In one channel mode, both relays are slaved to a single display channel and provide relay switching at two levels (ALERT and ALARM). In two channel mode, each display channel uses one relay which switches at the ALARM level.

Technical data

Measuring method:	vibration severity similar to ISO 10816 (modified lower freq., VDR-15/21)
Vibration channels:	1 (VDR-14/15), 2 (VDR-20/21)
Measuring range 1:	0-5 mm/s (0-0,19 inch/s)
Resolution:	3,2 mA = 1 mm/s; 1 mA = 0,313 mm/s
Measuring range 2:	0-10mm/s (0-0,39 inch/s)
Resolution:	1,6mA = 1 mm/s; 1 mA = 0,625 mm/s
Measuring range 3:	0-20mm/s (0-0,78 inch/s)
Resolution:	0,8 mA = 1 mm/s; 1 mA = 1,25 mm/s
Measuring range 4:	0-40mm/s (0-1,57 inch/s)
Resolution:	0,4 mA = 1 mm/s; 1 mA = 2,5 mm/s
Frequency range:	10 to 1000 Hz (VDR-14/20) 3 to 1000 Hz (VDR-15/21)
Transducer type:	SLD121, TRV18, TRV19
Transducer cable:	coaxial cable, SPM 90005-L, or 90267-L (L= max. 50 m)
Analog output:	4 to 20 mA, no galvanic separation
Fault indication:	≤ 1 mA out for open or short circuit
Loop resistance:	100 Ω. Higher resistance will reduce signal accuracy (max. 400 Ω at 12 V, 800 Ω at 24 V)
Power supply:	12 to 24V DC (± 10%, tested according to EN 50082-2), max 0.15 A
Design:	anodised aluminium, not protected
Input connectors:	TNC, silver plated brass, 10-15 μ
Output connectors:	screw terminals for cable max. 1.5 mm ² , connector plug included
Temperature range:	0 to 55 °C
Vibration exposure:	max. 5 mm/s RMS
Mounting:	19" rack
Dimensions:	3 U x 7 HP x 214 mm, DIN 41494
Weight:	200 g (VDR-14/15), 300 g (VDR-20/21)
Signal to display:	4 to 20 mA, 2 channels
Relays:	2, max. 24 V/100 mA
Value display:	3 digits, LED
Condition display:	green, yellow, and red LED
Alarm limits:	2 per display channel
Push-buttons:	2, for display control and programming

